



*Most Widely Accepted and Trusted*

# ICC-ES Evaluation Report

# ESR-2935

ICC-ES | (800) 423-6587 | (562) 699-0543 | [www.icc-es.org](http://www.icc-es.org)

Reissued 05/2018  
This report is subject to renewal 05/2020.

**DIVISION: 03 00 00—CONCRETE**  
**SECTION: 03 21 00—REINFORCING STEEL**

**REPORT HOLDER:**

**HEADED REINFORCEMENT CORP.**

**11200 CONDOR AVENUE**  
**FOUNTAIN VALLEY, CALIFORNIA 92708**

**EVALUATION SUBJECT:**

**HRC 555 HEADED REINFORCING BARS**



*“2014 Recipient of Prestigious Western States Seismic Policy Council (WSSPC) Award in Excellence”*



*ICC-ES Evaluation Reports are not to be construed as representing aesthetics or any other attributes not specifically addressed, nor are they to be construed as an endorsement of the subject of the report or a recommendation for its use. There is no warranty by ICC Evaluation Service, LLC, express or implied, as to any finding or other matter in this report, or as to any product covered by the report.*



# ICC-ES Evaluation Report

**ESR-2935**

Reissued May 2018

This report is subject to renewal May 2020.

[www.icc-es.org](http://www.icc-es.org) | (800) 423-6587 | (562) 699-0543

A Subsidiary of the International Code Council®

**DIVISION: 03 00 00—CONCRETE**  
**Section: 03 21 00—Reinforcing Steel**

**REPORT HOLDER:**

**HEADED REINFORCEMENT CORPORATION**  
11200 CONDOR AVENUE  
FOUNTAIN VALLEY, CALIFORNIA 92708  
(714) 557-1455  
[www.hrc-usa.com](http://www.hrc-usa.com)  
[engineer@hrc-usa.com](mailto:engineer@hrc-usa.com)

**EVALUATION SUBJECT:**

**HRC 555 HEADED REINFORCING BARS**

**1.0 EVALUATION SCOPE**

**Compliance with the following codes:**

- 2012 *International Building Code*® (IBC)
- 2013 *Abu Dhabi International Building Code* (ADIBC)<sup>†</sup>

<sup>†</sup>The ADIBC is based on the 2009 IBC. 2009 IBC code sections referenced in this report are the same sections in the ADIBC.

- Other Codes (see Section 8.0 for the 2006 IBC and Section 9.0 for the 2009 IBC)

**Property evaluated**

Structural

**2.0 USES**

HRC 555 headed reinforcing bars are mechanical devices complying with ACI 318-11 Section 12.6 as Class HA headed deformed bars for use as mechanical anchorage to develop the steel reinforcement bars in tension as an alternate to standard hooks or development lengths of straight deformed steel reinforcement bars in reinforced, normal-weight concrete. Related sections in ACI 318-11 that permit or require mechanical anchorage of reinforcing bars are Sections 12.1.1, 12.10.6, 12.11.2, 12.11.3, 12.11.4 and 12.12.1.

**3.0 DESCRIPTION**

**3.1 General:**

HRC 555 headed steel reinforcing bars are Class HA headed deformed bars complying with ASTM A970-09, which consists of a No. 4 (13 mm) through No. 11 (35 mm) reinforcing steel bar with a factory-forged head at one end or both ends of the bar. The net headed bearing area of the anchor head exceeds four times the nominal cross-sectional area of the bar. Dimensions and illustrations are provided in Table 1 and Figures 1 and 2.

**3.2 Material:**

The HRC 555 headed reinforcing bar is formed from deformed steel reinforcing bars complying with ASTM A706, Grade 60.

**4.0 DESIGN AND INSTALLATION**

**4.1 General:**

Structural design and installation must comply with HRC's installation instructions, ACI 318-11 Sections 12.6.1 through 12.6.3, and this evaluation report.

**4.2 Special Inspection:**

Special inspection must be provided at the jobsite as required by IBC Section 1704 and 1705. The inspector's duties include verifying grade and size of reinforcement bar, and verifying placement of the headed reinforcing bars and labeling of the products as noted in this evaluation report.

**5.0 CONDITIONS OF USE**

The HRC 555 headed reinforcing bar described in this report complies with, or is a suitable alternative to what is specified in, those codes listed in Section 1.0 of this report, subject to the following conditions:

- 5.1** The HRC 555 headed reinforcing bars must be installed in accordance with the code, the manufacturer's published instructions, and this report. In the case of conflict between the manufacturer's published instructions and this report, this report governs.
- 5.2** For structures regulated under Chapter 21 of ACI 318-11, with the HRC headed reinforcing bars resisting earthquake-induced flexural, axial force, or both, in special moment frames, special structural walls, and all components of special structural walls including coupling beams and wall piers, mill certificates of reinforcing bars must be submitted to the code official as evidence that the steel reinforcing bars comply with ACI 318-11 Section 21.1.5.2.
- 5.3** Special inspections must be provided in accordance with Section 4.2 of this report.
- 5.4** Minimum concrete cover must be in accordance with Section 7.7 of ACI 318-11, and must be measured from the outer surface of the HRC 555 headed reinforcing bar's head.
- 5.5** When steel reinforcing bars are headed at a fabricator's facility to form the HRC 555 headed reinforcing bar, the following statements apply:
  - 5.5.1** The fabricator must be approved by the code official in accordance with IBC Section 1704.2.

- 5.5.2** The fabricator must be approved by the report holder, HRC.
- 5.5.3** The fabricator must demonstrate, to the satisfaction of the code official, compliance with the XT-2 Operating Manual, , as defined by HRC.
- 5.5.4** For each HRC 555 headed steel reinforcing bar size, the fabricator must demonstrate to the satisfaction of the code official that the headed steel reinforcing bars are consistent with the qualifying test specimens. This may be demonstrated in test reports submitted to the code official.
- 5.6** HRC 555 headed reinforcing bar calculations and installation details for each project complying with the IBC and ACI 318 must be submitted to the code official for approval, with this information prepared by a registered design professional when required by the statutes of the jurisdiction in which the headed bars are installed.
- 5.7** The HRC 555 headed reinforcing bar that is headed by Headed Reinforcement Corporation (HRC) is formed/headed in Fountain Valley, California, under a quality control program with inspections by ICC-ES. All other heading operations must comply with Section 5.5, above.

## 6.0 EVIDENCE SUBMITTED

Data in accordance with the ICC-ES Acceptance Criteria for Headed Deformed Bars (AC347), dated January 2013.

## 7.0 IDENTIFICATION

### 7.1 Reinforcing Bars Headed by HRC:

HRC 555 headed reinforcing bar manufactured by HRC is labeled with the bar size, the product name (HRC 555), the letters "HA" to indicate conformance with ASTM A970-09, the symbol "F01" to indicate the product having been manufactured at HRC's facility, and the ICC-ES evaluation report number (ESR-2935).

### 7.2 Reinforcing Bars Headed by Fabricator:

HRC 555 headed reinforcing bar manufactured by a fabricator approved by the code official must be labeled with the bar size, the product name (HRC 555), the letters "HA" to indicate conformance with ASTM A970-09, and includes initials or other unique identifiers of the approved fabricator's facility. The headed deformed bars must be accompanied to the jobsite with paperwork, as required by the code official, indicating the headed reinforcing bars were manufactured by the fabricator approved by the code official per Section 5.5 of this report.

## 8.0 2006 International Building Code® (IBC).

### 8.1 Evaluation Scope:

In addition to the code referenced in Section 1.0, the products in this report were evaluated for compliance with the requirements of the 2006 *International Building Code*® (IBC). The HRC 555 headed reinforcing bars, as described in this report, are suitable alternatives to what is specified in the 2006 IBC, subject to the provisions of Section 8.2 through 8.7.

### 8.2 Uses:

The HRC 555 headed bar is a mechanical device complying with ACI 318-05 Section 12.6, for use as mechanical anchorage to develop the steel reinforcement bars in tension as an alternate to standard hooks or development lengths of straight deformed steel reinforcement bars in reinforced, normal-weight concrete. Related sections in ACI 318 that permit or require mechanical anchorage of reinforcing bars are Sections.

12.1.1, 12.10.6, 12.11.2, 12.11.3, 12.11.4 and 12.12.1.

HRC 555 headed bars can also be used as an alternative to tension lap splices specified by ACI 318-05 Section 12.15.

### 8.3 Description:

See Section 3.0.

### 8.4 Design and Installation:

#### 8.4.1 General:

The installation parameters of the HRC 555 headed deformed bars (including the concrete compressive strength, headed bar spacing, concrete coverage and headed deformed bar anchorage length) must be such that the reinforcing bar tensile force based on the headed end concrete bearing strength,  $f_{c,bear}$ , exceeds the tensile force at specified yield strength,  $f_y$ , of the reinforcing bar according to Section 8.4.2, and the headed bars are installed in accordance with Section 8.4.2. The minimum anchorage length and minimum lapped splice length of the headed deformed bars must comply with Sections 8.4.3 and 8.4.4, respectively.

#### 8.4.2 Installation Parameters:

The headed deformed bars must be placed so that  $c_p/d_b$  is equal to or greater than 2.5, and the installation parameters must satisfy Eq-1:

$$f_{c,bear} \times A_{brg} \geq f_y \times A_b, \text{ pounds (N)} \quad (\text{Eq-1})$$

where:

$$f_{c,bear} = 0.6f'_c \omega_t(2c_b) / (A_{brg})^{0.5} < 8f'_c, \text{ psi (Pa)}$$

$$\omega_t = 0.6 + 0.4 (c_2/c_b) < 2.0$$

$f'_c$  = Specified 28-day concrete compressive strength with the maximum value of  $f'_c$  to be used in the calculation limited to 6,000 psi (41.3 MPa) [minimum of 24 MPa is required under ADIBC Appendix L, Section 5.1.1].

$c_b$  = The minimum of half the center-to-center reinforcing bar spacing or the least overall concrete cover dimension measured to the center of the reinforcing bar, inches (mm).

$c_2$  = Dimension orthogonal to  $c_b$ , inches (mm). If  $c_b$  is determined by half the center-to-center reinforcing bar spacing,  $c_2$  is the lesser of the concrete cover in the orthogonal direction measured to the center of the reinforcing bar or half the center-to-center reinforcing bar spacing orthogonal to  $c_b$ .  $c_2$  must always be equal to or greater than  $c_b$ .

$A_{brg}$  = Net headed bearing area as specified in Table 1, square inches (mm<sup>2</sup>).

$A_b$  = Nominal cross-sectional area of the reinforcing bar as specified in Table 1, square inches (mm<sup>2</sup>).

$f_y$  = Specified yield strength of the reinforcing bar, psi (MPa).

$d_b$  = Reinforcing bar nominal diameter, inch (mm).

#### 8.4.3 Minimum Anchorage Length:

The minimum anchorage length,  $L_a$ , of headed deformed bars must be eight times the steel reinforcing bar diameter or 6 inches (152 mm), whichever is greater. (See Table 1.) Anchorage length is defined as the distance from the critical section to the concrete bearing face of the headed end of the headed deformed bar. Critical section is defined as that location in the concrete member where the full steel bar stress is required.

**8.4.4 Headed Bar Lap Splices:**

When HRC 555 headed deformed bars are used as an alternative to the code-required lapped splices of deformed bar reinforcement, the minimum lap length,  $L_s$ , as measured between bearing faces of opposing heads of the headed deformed bars, must be in accordance with Eq-2 defined below (see Figure 2):

$$L_s = 1.3(L_a + S_b \tan 35^\circ) \quad (\text{Eq 2})$$

where:

$L_a$  = Minimum anchorage length, inches (mm).

$S_b$  = Centerline spacing between lapped headed bars, inches (mm).

**8.4.5 Termination of Headed Deformed Reinforcing Bars:**

Longitudinal headed deformed reinforcing bars originating in members, such as (but not limited to) beams, corbels, or brackets, and terminated in an adjacent member, must be extended to the far face of the confined region of the adjacent member.

**8.4.6 Special Inspection:**

Special inspection must be provided at the jobsite as required by IBC Section 1704. The inspector's duties include verifying grade and size of reinforcement bar, and verifying placement of the headed reinforcing bars and labeling of the products as noted in this evaluation report.

**8.5 Conditions of Use:**

See Section 5.0, but replace the wording in Sections 5.2, 5.3 and 5.4 with the following:

Replacement for Section 5.2:

For structures regulated under Chapter 21 of ACI 318-05 (as modified by IBC Section 1908), with the mechanical anchors resisting earthquake-induced flexural and axial forces in frame members and in structural wall boundary elements with the HRC 555 system, mill certificates of reinforcing bars must be submitted to the code official as evidence that the steel reinforcing bars comply with ACI 318-05 Section 21.2.5 (denoted as ACI 318 Section 21.2.5.1 in IBC Section 1908.1.5).

Replacement for Section 5.3:

Special inspections must be provided in accordance with Section 8.4.6 of this report.

Replacement for Section 5.4:

Minimum concrete cover must be in accordance with Section 1907.7 of the IBC, and must be measured from the outer surface of the HRC 555 headed reinforcing bar's head.

**8.6 Evidence Submitted:**

Data in accordance with the ICC-ES Acceptance Criteria for Headed Ends of Concrete Reinforcement (AC347), dated August 2008.

**8.7 Identification:****8.7.1 Reinforcing Bars Headed by HRC:**

HRC 555 headed reinforcing bar manufactured by HRC is labeled with the bar size, the product name (HRC 555), the symbol "T" to indicate conformance with ASTM A970-06, the symbol "F01" to indicate the product having been manufactured at HRC's facility, and the ICC-ES evaluation report number (ESR-2935).

**8.7.2 Reinforcing Bars Headed by Fabricator:**

HRC 555 headed reinforcing bar manufactured by a fabricator approved by the code official must be labeled with the bar size, the product name (HRC 555), the symbol "T" to indicate conformance with ASTM A970-06, and includes initials or unique identifiers of the approved fabricator's facility. The headed deformed bars must be accompanied to the jobsite with paperwork as required by the code official indicating the headed reinforcing bars were manufactured by the fabricator approved by the code official per Section 5.5 of this report.

**9.0 2009 International Building Code® (IBC)****9.1 Evaluation Scope:**

In addition to the code referenced in Section 1.0, the products in this report were evaluated for compliance with the requirements of the 2009 *International Building Code*® (IBC). The HRC 555 headed reinforcing bars described in this report comply with, or are suitable alternatives to what is specified in, the 2009 IBC, subject to the provisions of Section 9.2 through 9.7.

**9.2 Uses:**

HRC 555 headed reinforcing bars are mechanical devices complying with ACI 318-08 Section 12.6, for use as mechanical anchorage to develop the steel reinforcement bars in tension as an alternate to standard hooks or development lengths of straight deformed steel reinforcement bars in reinforced, normal-weight concrete. Related sections in ACI 318-08 that permit or require mechanical anchorage of reinforcing bars are Sections 12.1.1, 12.10.6, 12.11.2, 12.11.3, 12.11.4 and 12.12.1.

**9.3 Description:**

See Section 3.0.

**9.4 Design and Installation:**

**9.4.1** Structural design and installation must comply with HRC's installation instructions, ACI 318-08 Sections 12.6.1 through 12.6.3, and this evaluation report.

**9.4.2 Special Inspection:**

Special inspection must be provided at the jobsite as required by IBC Section 1704 and 1705. The inspector's duties include verifying grade and size of reinforcement bar, and verifying placement of the headed reinforcing bars and labeling of the products as noted in this evaluation report.

**9.5 Conditions of Use:**

See Section 5.0, but replace the wording in Sections 5.2, 5.3 and 5.4 with the following:

Replacement for Section 5.2:

For structures regulated under Chapter 21 of ACI 318-08, with the mechanical anchors resisting earthquake-induced flexural and axial forces in frame members and in structural wall boundary elements with the HRC 555 system, mill certificates of reinforcing bars must be submitted to the code official as evidence that the steel reinforcing bars comply with ACI 318-05 Section 21.1.5.2.

Replacement for Section 5.3:

Replacement for Section 5.4:

Minimum concrete cover must be in accordance with Section 7.7 of ACI 318-08, and must be measured from the outer surface of the HRC 555 headed reinforcing bar's head.

**9.6 Evidence Submitted:**

Data in accordance with the ICC-ES Acceptance Criteria for Headed Ends of Concrete Reinforcement (AC347), dated February 2010.

**9.7 Identification:**

**9.7.1 Reinforcing Bars Headed by HRC:**

HRC 555 headed reinforcing bar manufactured by HRC is labeled with the bar size, the product name (HRC 555), the symbol "T" to indicate conformance with ASTM A970-06, the symbol "F01" to indicate the product having been manufactured at HRC's facility, and the ICC-ES evaluation report number (ESR-2935).

**9.7.2 Reinforcing Bars Headed by Fabricator:**

HRC 555 headed reinforcing bar manufactured by a fabricator approved by the code official must be labeled with the bar size, the product name (HRC 555), the symbol "T" to indicate conformance with ASTM A970-06, and include initial or unique identifiers of the approved fabricator's facility. The headed deformed bars must be accompanied to the jobsite with paperwork, as required by the code official, indicating the headed reinforcing bars were manufactured by the fabricator approved by the code official per Section 5.5 of this report.

**TABLE 1—DIMENSIONS OF HRC 555 HEADED REINFORCING BARS**

Dimensions	Bar size	#4	#5	#6	#7	#8	#9	#10	#11
Rebar	Diameter, $d_b$ [in]	0.500	0.625	0.750	0.875	1.000	1.128	1.270	1.410
	Area [sq.in.]	0.20	0.31	0.44	0.60	0.79	1.00	1.27	1.56
Head	* $T_{min}$ [in]	0.25	0.31	0.38	0.44	0.5	0.56	0.64	0.70
	D [in]	1.14	1.42	1.69	1.97	2.25	2.56	2.87	3.19
	$A_{brg}$ [sq.in.]	0.82	1.27	1.80	2.45	3.18	4.14	5.20	6.43

For SI: 1 inch = 25.4 mm, 1 sq.in. = 645 mm<sup>2</sup>, 1 foot = 305 mm. \* Head thickness should be no larger than bar diameter.

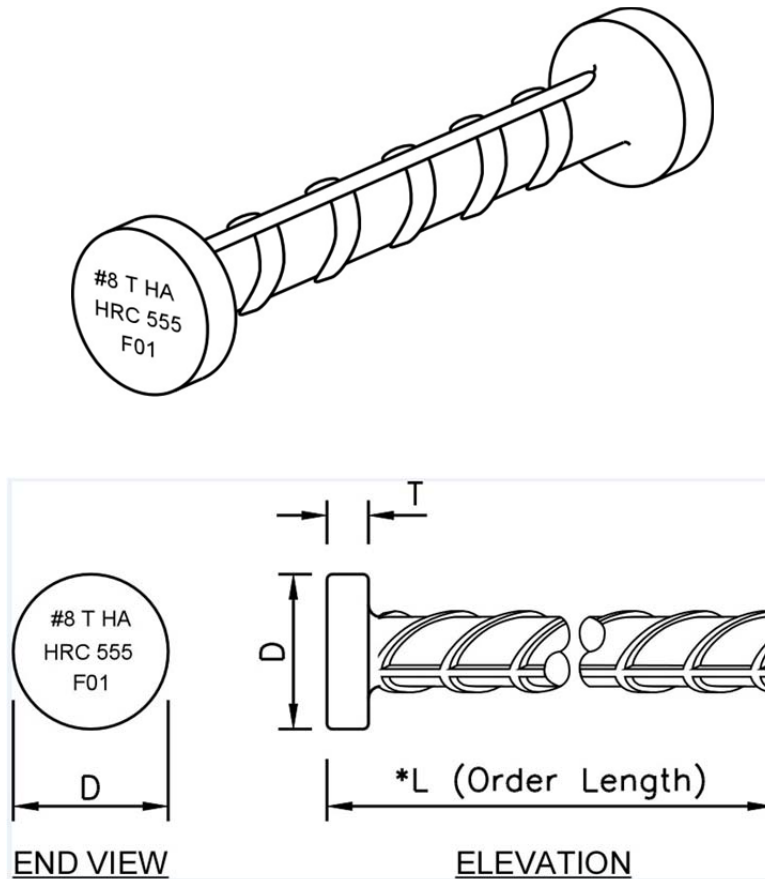

**FIGURE 1—HRC 555**  
 The "T" is for the 2006 and 2009 IBC.  
 The "HA" is for the 2012 IBC



TABLE 2—HEADED LAP SPLICES (2006 IBC) <sup>1</sup>

Bar size	#4	#5	#6	#7	#8	#9	#10	#11
Minimum Anchorage Length, $L_a$ [in]	6.00	6.00	6.00	7.00	8.00	9.02	10.16	11.28
Center spacing, $S_b = 1.65 d_b$ [in]	0.83	1.03	1.24	1.44	1.65	1.86	2.10	2.33
Minimum Lap Length, $L_s$ [in]	8.55	8.74	8.93	10.41	11.90	13.43	15.12	16.78
Comment:	<b>Minimum spacing (edge of head touch spliced bar)</b>							
Center spacing, $S_b = 2.5 d_b$ [in]	1.25	1.56	1.88	2.19	2.50	2.82	3.18	3.53
Minimum Lap Length, $L_s$ [in]	8.94	9.22	9.51	11.09	12.68	14.30	16.10	17.87
Comment:	<b>Clear spacing between heads during installation</b>							

For **SI**: 1 inch = 25.4 mm.

<sup>1</sup> This table is limited to use under the 2006 IBC.

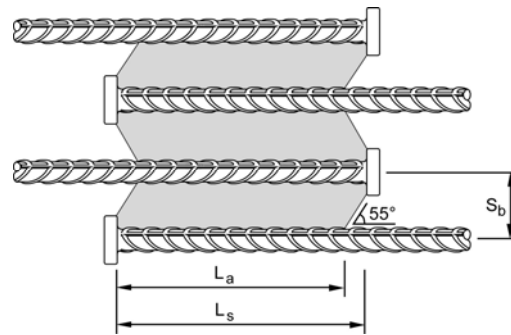

FIGURE 2—HRC 555 LAP SPLICE (2006 IBC)